



james
MARTIN



Table Blender ZX841

Safety first
Never touch the blades while the appliance is plugged in.
Always read your instructions before using for the first time.

Please read all instructions carefully to familiarize yourself with the Wahl James Martin Table Blender before using.

THIS TABLE BLENDER IS INTENDED FOR HOUSEHOLD USE ONLY.

Save these instructions for further reference.

For any further assistance or information call customer services on

T: 01227 740066

or visit

W: www.wahl.co.uk

E: customer.services@wahl.co.uk

INDEX

DESCRIPTION OF PARTS	Page 3
IMPORTANT SAFEGUARDS	Page 4
HOW TO USE	Page 5
CLEANING AND MAINTENANCE	Page 8
RECIPES	Page 10
WIRING	Page 14
PRODUCT REGISTRATION	Page 15
GUARANTEE	Page 15

DESCRIPTION OF PARTS

- A: Measuring Cup
- B: Lid
- C: Glass Jug
- D: Handle
- E: Rubber Seal
- F: Blade
- G: Blade Housing
- H: Main Body
- I: Speed Control Dial
- J: Grinder Attachment

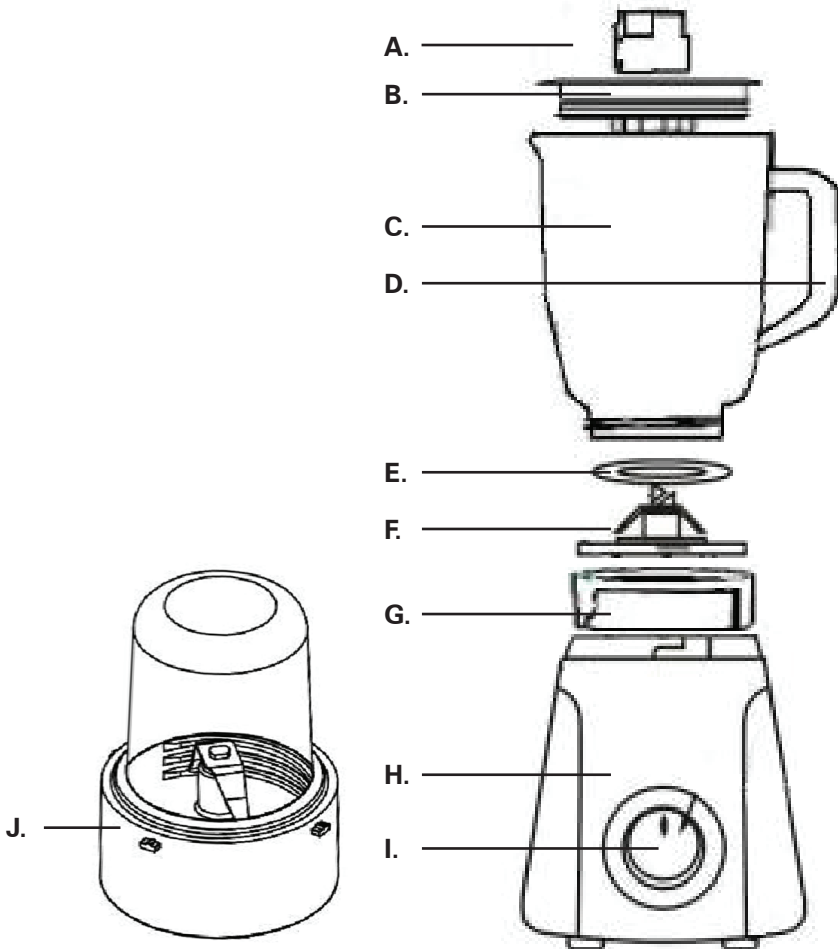

IMPORTANT SAFEGUARDS

When using this electrical appliance, especially when children are present, basic safety precautions should always be observed including the following.

TO REDUCE THE RISK OF FIRE AND INJURY

1. This appliance is not intended for use by persons (including children) with reduced physical, sensory or mental capabilities, or lack of experience and knowledge, unless they have been given supervision or instruction concerning use of the appliance by a person responsible for their safety. Children should be supervised to ensure that they do not play with the appliance.
2. Never touch or allow contact with moving parts while in motion. Keep hands, hair clothing and other utensils away from the moving parts during operation to prevent accident, injury or damage to the appliance.
3. Switch off the appliance and unplug from outlet when not in use, before putting on or taking off attachments and also before cleaning the appliance.
4. Never use your appliance without paying attention! Always unplug the unit when not in use, even for a moment.
5. Do not operate the appliance with a broken cord or plug, or if the appliance malfunctions, or is dropped or damaged in anyway.
6. Any servicing or repair must be performed by an authorized service representative.
7. Do not use outdoors or in damp areas.
8. Do not let the cord hang over the edge of the work surface or let it touch any hot surfaces.
9. The use of attachments that are not supplied by the manufacturer may cause fire, electric shock or injury and damage to the appliance.
10. To protect against risk of electrical shock, never immerse the unit or let it come into contact with water or any other liquids. Do not use the unit with wet hands. If the appliance should become wet, damp or fall in water, remove plug from mains socket immediately. Do not put your hands in the water.

11. Never carry the unit by its power cord.
12. Use this appliance only for its intended purpose.

INSTALLATION

1. Remove all packaging and clean the jug, measuring cup and lid thoroughly before using for the first time. Only clean the main unit with a damp cloth. Never immerse the unit in water or place under running water. See cleaning & storage section page 8 for full cleaning instructions.
The blender should be placed on flat surface before operation.

⚠ WARNING: THE BLADE IS VERY SHARP. WASH WITH CARE AND NEVER TOUCH THE BLADE WITH YOUR FINGERS.

2. Do not plug in the appliance before assembling.
3. Place the appliance on a flat surface.
4. Place the glass jug on to the motor unit and lock into place by turning clockwise.
5. Put the lid on top of the jug and push it down. Insert the measuring cup into the cover and turn until it locks into place.
6. Make sure the appliance is turned off before plugging in.

HOW TO USE

1. Before plugging in ensure that the mains voltage matches that shown on the rating label.
2. This unit has a safety design, it will not work if the jug is not installed onto the main body properly.
3. Turn the control dial to position 0 in order to make sure the unit is turned off.
4. Place ingredients into the jug, do not exceed the maximum 1.5L capacity.

IMPORTANT: Do not operate with out any ingredients.

5. Put the cover on top of the jug ensuring it is fitted correctly.
6. Turn the control dial clockwise to your desired speed as you need, or use the pulse function by turning the dial anti-clockwise.

IMPORTANT: Do not open the lid while the blender is working.

CONTROL SETTINGS

- P - Pulse. The pulse setting will operate at the highest speed, and will only operate when you are holding the switch, as soon as you release the switch the appliance will stop. This is suitable for ice and for when you only want to roughly blend ingredients and you require control so that you don't end up with a really fine mixture.
- 1 - Low Speed. Will blend continuously on Low speed until you return the switch to the off position.
- 2 - High Speed. Will blend continuously on High speed until you return the switch to the off position.
- 0 - Off. Will turn off the unit.

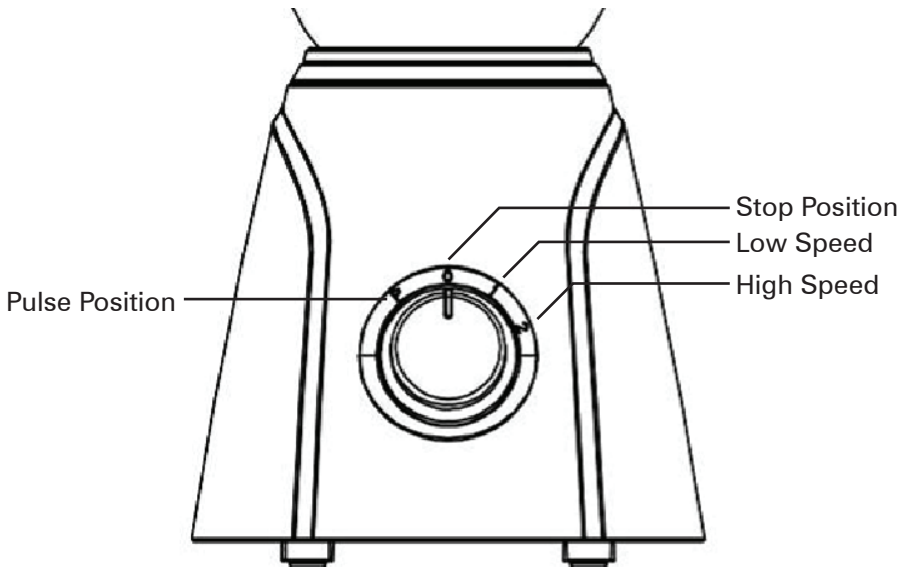

7. Turn the dial to the "OFF" position when you have finished. Wait for the blender to completely stop.
Unplug the appliance before removing the lid or the jug.
8. Always ensure the appliance is unplugged after use.

NOTE: It is recommended to cut the meat, vegetables or other food into smaller pieces before putting them in the jug. Large quantities of food should be processed in small batches, do not overload.

Do not operate the appliance continuously for more than 1 minute. Always allow the appliance to cool down to room temperature before continuing.

⚠ WARNING: ALWAYS COOL HOT LIQUIDS BEFORE BLENDING.

NOTE: If blending warm liquids remove the measuring cap and start at low speed increasing to high speed if required. The pulse setting is not recommended for warm liquids. Do not blend warm liquids over the 1L level, and always take care to avoid contact with any steam or liquids.

USING THE GRINDING ATTACHMENT

1. Make sure the unit is unplugged and turned off before installation of the grinder attachment.
2. The grinder can be used for nuts, dried fruit, bread crumbs etc.
3. Turn grinder upside down and carefully unscrew the blade housing. Carefully remove the housing, blade and rubber seal.
4. Fill the grinder with desired ingredients. Do not fill more than half full.
5. Ensure the rubber seal is in place. See illustration below.
The rubberised seal fits either side of the blade assembly place the blade onto the glass bowl.

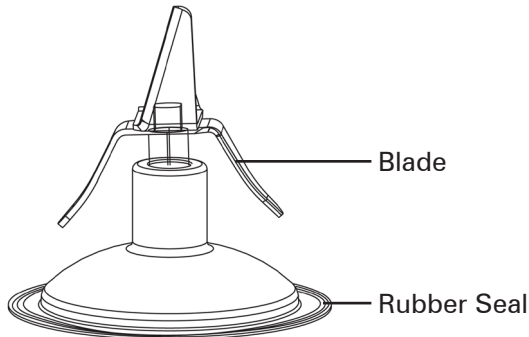

6. Screw the blade housing tightly on to the glass bowl.
7. Turn the grinder the right way up and lock into place on the motor unit by turning clock wise.
8. Plug the appliance in and select desired speed setting.
9. When the ingredients have been grounded/chopped to the desired consistency, unplug the appliance, and remove the grinding unit from the appliance.

NOTE: Always unplug and remove the complete grinding unit. Do not unscrew the glass bowl on the unit. As this will cause the ingredients to spill out and expose the blade unit.

10. Turn the grinder upside down and carefully unscrew the blade housing. Carefully remove the housing, blade and rubber seal, and empty the ingredients into a bowl etc.

CLEANING AND STORAGE

GRINDER ATTACHMENT

1. In addition to the following you must refer to the safety precautions.
2. Turn grinder upside down and carefully unscrew the blade housing. Carefully remove the housing, blade and rubber seal. Clean with hot water and a little mild cleaning agent taking great care as the blades are very sharp.
3. Ensure the bowl and blades and rubber seal are clean, rinse and dry well before re-using.
4. Never use aggressive cleaning agents.

⚠WARNING: DO NOT TOUCH THE SHARP BLADES, WHEN CLEANING PLEASE WIPE WITH A CLOTH TO AVOID ACCIDENTAL INJURY.

CLEANING AND STORAGE BLENDER AND JUG

1. In addition to the following you must refer to the safety precautions.
2. Do not clean motor main body, power cord and plug with water.
3. Clean the main body with a soft, damp cloth and some mild cleaning agent.
4. Fill the jug half-full with warm water and a little cleaning agent. Let the unit run on speed 2 until the jug is clean.
5. Ensure the jug and blades are clean, rinse and dry well before re-using.

⚠WARNING: THE BLADES INSIDE OF THE JUG ARE VERY SHARP.

6. Never use aggressive cleaning agents.

REMOVABLE BLADES

The blades of your Wahl James Martin Table blender are removable and can be removed for cleaning. Please ensure that you read the following instructions carefully.

1. Ensure the appliance is turned off and unplugged.
2. Remove the jug assembly from the base and unscrew the blade

housing from the glass jug.

3. Carefully remove the rubber seal and blades and wash with mild cleaning agent taking great care as the blades are sharp.
4. Dry all parts carefully.

TO REASSEMBLE

1. Ensure the blade and rubber seal are replaced with the rubber seal against the glass and ensure the blade housing is tightly screwed back onto the glass jug.

IMPORTANT: Always unplug the main housing and remove the complete jug assembly before attempting to unscrew the blade housing.

IMPORTANT: Never place or store the blade housing on the main unit whilst removed from the jug.

RECIPES

PUMPKIN SOUP

Serves 4

1kg / 2 ¼ lb pumpkin squash
1 banana shallot, peeled and roughly chopped
2 Cloves garlic peeled and crushed
500 ml / 18floz fresh chicken stock
150 ml / 5 fl oz Double cream
Drizzle Virgin olive oil
50g / 2oz crème fraiche
2 tbsp chives, finely chopped
Seasoning

1. Firstly peel and remove the seeds from the pumpkin, dice into 1inch chunks.
2. Put the onion, garlic and pumpkin in a large pan with a little olive oil over a medium heat, Colour slightly then add the stock and bring to the boil.
3. Simmer for about 10 – 15 minutes to cook the pumpkin.
4. Allow the mixture to cool and place the soup into the James Martin Table Blender with the cream and blend. Season with salt and pepper.
5. Place back in the pan on the heat and check seasoning gently warm but don't boil.
6. Place in the bowl with a dollop of crème fraiche, drizzle a little olive oil over, add a scattering of chives and serve.

RECIPES

LEEK, POTATO AND STILTON SOUP

Serves 4-6

1 medium-sized leek, split and washed
1 large baking potato
130g strong stilton
2 cloves garlic
1 shallot
1 chicken stock cube
1pt hot water
125ml double cream
100ml white wine
5g parsley
Seasoning
1 packet of shop bought croutons
basil leaves

1. Firstly, peel the garlic, shallot and potato and chop into small pieces.
2. Place the stock cube, water and wine into a pan and put on to boil.
3. Thinly slice the leek and add to the pan together with the shallot, garlic and potato.
4. Add the Stilton and cover. Cook for 4-5 minutes to cook the potatoes.
5. Add the cream, parsley and seasoning and allow to cool.
6. Using the James Martin Table Blender, blend in batches to a fine mix.
7. Return to the pan, bring to the boil and season.
8. Serve in a bowl with the croutons on the top, a swirl of double cream and a basil leaf.

RECIPES

WATERCRESS SOUP

Serves 4-6

1 onion, sliced
2 cloves garlic, chopped
25g (1oz) butter
1.2 litres (2 pints)
chicken stock
450g (1lb) Estima
potatoes, peeled and diced
2 bunches watercress
freshly grated nutmeg, (optional)
200ml (7fl oz) double cream
salt and pepper, to taste

1. In a heavy-bottomed saucepan, fry the onion and garlic in the butter until softened but not coloured.
2. Add the stock and potatoes and bring to the boil. Simmer for 15-20 minutes, until the potatoes are cooked.
3. Chop up the watercress (leaves and stalks) and add to the soup with the freshly ground nutmeg, if using.
4. Simmer for 2-3minutes before cooling and blending in the James Martin Table Blender in batches, adding the cream as you go.
5. Return to the pan and heat through gently and season with salt and pepper.

CRANBERRY AND RASPBERRY SMOOTHIE

Serves 4

200ml cranberry juice
1 punnet of fresh raspberries
100ml semi skimmed milk
200g plain yoghurt
1dsp caster sugar

1. Place all the ingredients into a mini blender and pulse until all of the ingredients are combined then pour into glasses and serve with a sprig of fresh mint.

RECIPES

PAN FRIED COD WITH SALSA VERDE

Serves 2

40g mixed herbs:

flat parsley, chervil, mint, basil and thyme

10g capers

10g gherkins

3 spring onions

1 ½ lemons, juice and zest

100-125 fl virgin

olive oil

2 x 6oz thick

cod fillets

1oz butter

seasoning

1. In a hot non-stick frying pan, add the butter and a little olive oil.
2. Season the cod fillets and once the butter is foaming, pan-fry on both sides for between 2-3 minutes, until golden brown.
3. To make the salsa, chop up the spring onions and place in the James Martin Table Blender with the lemon juice and zest, gherkins, capers and herbs. Blend while slowly adding the olive oil to a paste.
4. Season with salt and pepper. Simply serve on top of the pan-fried cod.

WIRING

⚠ WARNING: IF THE SUPPLY CORD IS DAMAGED IT MUST BE REPLACED BY THE MANUFACTURERS SERVICE AGENT OR A SIMILARLY QUALIFIED PERSON IN ORDER TO AVOID A HAZARD.

The wires in the mains lead of this Table Blender are coloured in accordance to the following code:

Blue Neutral (N) Brown live (L)

This appliance is fitted with a 3 pin plug which has a 13amp fuse fitted.

If the plug supplied is not suitable for your socket or becomes damaged, it should be cut off and disposed of, and a suitable plug fitted as detailed below.

As the colours of the wires in the mains lead of this Food Processor may not correspond with the colour markings identifying the terminals in your plug, proceed as follows.

The wire which is coloured BLUE must be connected to the terminal in the plug which is marked with the letter 'N' or coloured BLACK or BLUE.

The wire which is coloured BROWN must be connected to the terminal in the plug which is marked with the letter 'L' or coloured RED or BROWN.

DO NOT connect either wire to the terminal in the plug which is marked with the letter 'E' or has the Earth symbol, or coloured GREEN or GREEN/YELLOW

PRODUCT REGISTRATION

Wahl are constantly developing and launching new products in the UK. We would like to understand your product needs and expectations and we value any comments you may have. As part of Wahl Customer Care, we are offering you the chance to be kept up to date with the latest product launches, innovations and special offers.

Please take a minute to register your product online at www.wahl.co.uk.

WASTE ELECTRICAL & ELECTRONIC EQUIPMENT DIRECTIVE 2002/96/EC (WEEE)



At the end of this products life it should not be disposed of with general household waste.

Care should be taken to dispose of in a suitable manner in accordance with your Local Authority regulation.

GUARANTEE

This product is guaranteed against defects in material and workmanship for a period of 2 years from the date of original purchase or receipt as a gift.

Should this product become defective during the guarantee period, return it to the store of purchase together with your proof of purchase for repair or replacement

Alternatively within the guarantee period you can return the product to Wahl (UK) Ltd who will repair any such defect or elect to replace the product or any part of it, without charge, provided that there is proof of purchase. Should a replacement be offered this will not extend the original guarantee period.

The guarantee becomes invalid in the case of misuse, alteration or repair by unauthorised persons.

This product is designed for domestic use only and use within a professional environment will invalidate the guarantee.

This guarantee in no way affects your rights under statutory law in the United Kingdom.

Wahl (UK) Ltd
Herne Bay Trade Park
Herne Bay
Kent
CT6 8JZ
www.wahl.co.uk

Customer Service T: 01227 740066

Form No. ZB093
Rev2 10-14

