



james
MARTIN

by

WAHL®

Food Processor ZX835

Safety first

The blades of this appliance are extremely sharp, take great care.
Always unplug before adding or removing attachments.
Read all instructions before using for the first time.

James Martin Food Processor

Please read all instructions carefully to familiarise yourself with the Wahl James Martin Food Processor before using.

THIS FOOD PROCESSOR IS INTENDED FOR HOUSEHOLD USE ONLY.

Save these instructions for further reference.

For any further assistance or information call customer services on

T: 01227 740066

or visit

W: www.wahl.co.uk

E: customer.services@wahl.co.uk

CONTENTS

| | |
|---------------------------------|---------|
| DESCRIPTION OF PARTS | Page 3 |
| IMPORTANT SAFEGUARDS | Page 4 |
| HOW TO USE | Page 6 |
| CLEANING AND MAINTENANCE | Page 9 |
| TROUBLESHOOTING | Page 9 |
| WIRING | Page 10 |
| PRODUCT REGISTRATION | Page 11 |
| GUARANTEE | Page 11 |

DESCRIPTION OF PARTS

- A: Small Pusher
- B: Large Pusher with small Feeder Tube
- C: Processor Lid
- D: Processor Bowl
- E: Drive Shaft
- F: Control Dial
- G: Main Body
- H: Stainless Steel Blade
- I: Slicing and Grating Disk
- J: Filler Cap
- K: Blender Lid
- L: 1.5L Blender Jug
- M: Sealing Ring
- N: Blade

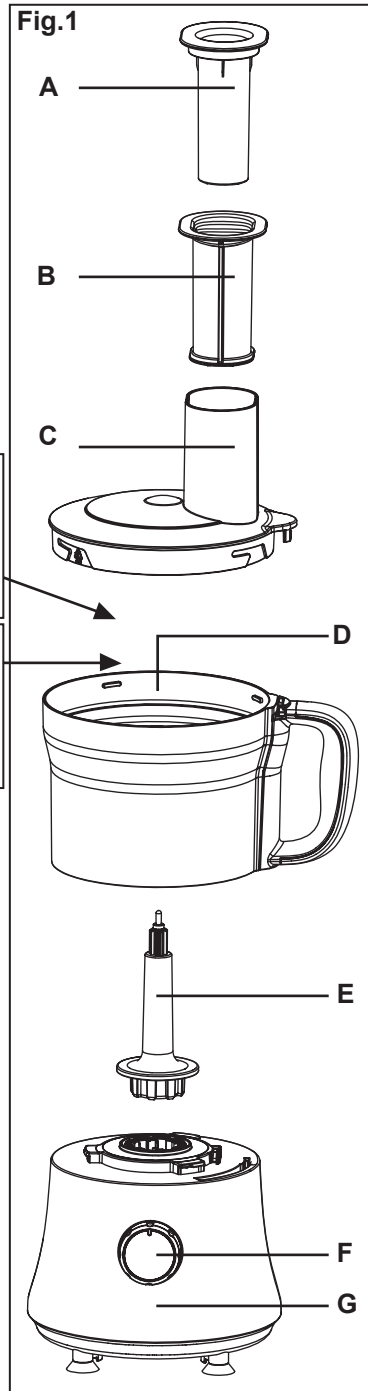
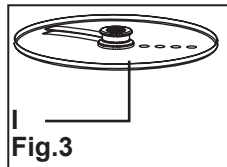
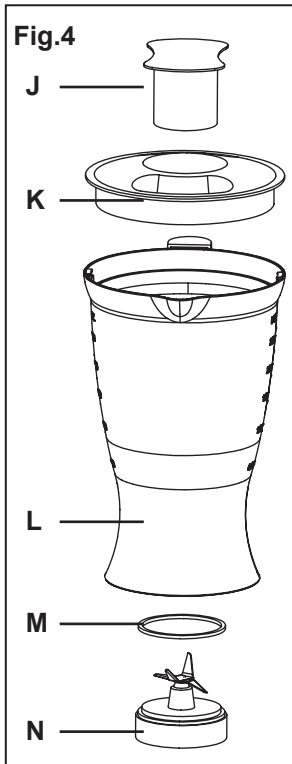

The appliance is fitted with safety features that will not allow it to function unless it is correctly assembled.

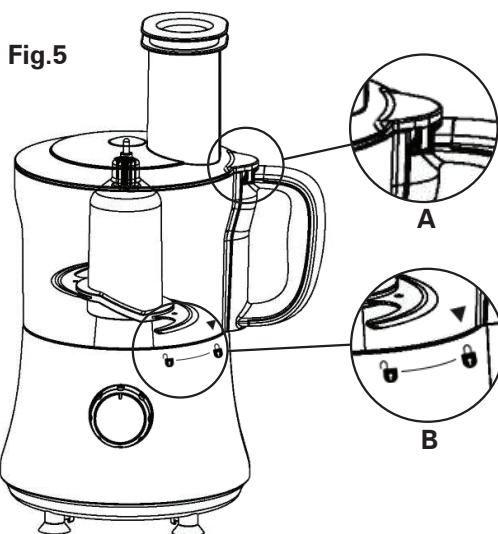

To operate the processor, always ensure the processor lid (Fig.5A) and the processor bowl (Fig.5B) are securely locked into place with the markings lined up.

To operate the blender, always ensure the blender jug (Fig.5C) is securely locked into place with the markings lined up.

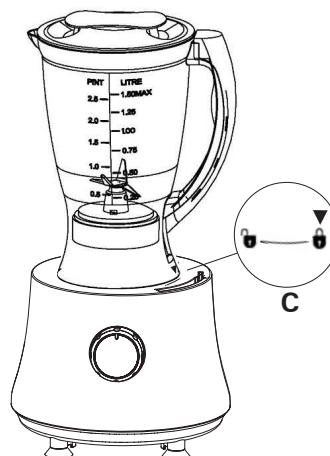

IMPORTANT SAFEGUARDS

When using this electrical appliance, especially when children are present, basic safety precautions should always be observed including the following.

TO REDUCE THE RISK OF FIRE AND INJURY

1. This appliance is not intended for use by children.
2. Children should be supervised to ensure that they do not play with the appliance.
3. This appliance can be used by persons with reduced physical, sensory or mental capabilities or lack of experience and knowledge if they have been given supervision or instruction concerning the use of the appliance in a safe way and

understand the hazards involved.

4. Never touch or allow contact with moving parts while in motion. Keep hands, hair clothing and other utensils away from the moving parts during operation to prevent accident, injury or damage to the appliance.
5. Switch off the appliance and unplug from outlet when not in use, before putting on or taking off attachments and also before cleaning the appliance.
6. Never use your appliance without paying attention! Always unplug the unit when not in use, even for a moment.
7. Do not operate the appliance with a broken cord or plug, or if the appliance malfunctions, or is dropped or damaged in anyway.
8. Any servicing or repair must be performed by an authorised service representative.
9. Do not use outdoors or in damp areas.
10. Do not let the cord hang over the edge of the work surface or let it touch any hot surfaces.
11. The use of attachments that are not supplied by the manufacturer may cause fire, electric shock or injury and damage to the appliance.
12. To protect against risk of electrical shock, never immerse the unit or let it come into contact with water or any other liquids. Do not use the unit with wet hands. If the appliance should become wet, damp or fall in water, remove plug from mains socket immediately. Do not put your hands in the water.
13. Never carry the unit by its power cord.
14. Use this appliance only for its intended purpose.
15. This appliance is intended to be used in household and similar applications such as:
 - Staff kitchen areas in shops, offices and other working environments.
 - Farm houses
 - By clients in hotels, motels and other residential type environments
 - Bed and breakfast type environments

HOW TO USE

Before plugging in make sure that the local voltage matches that shown on the rating label.

BEFORE FIRST USE

1. Remove all packaging and familiarise yourself with your Food Processor components as listed in the Description Of Parts on page 3.
2. Wash and clean the processor parts as described in the section Cleaning and Maintenance.

⚠ WARNING: THE BLADES OF THIS FOOD PROCESSOR ARE EXTREMELY SHARP! DO NOT TOUCH THE BLADES.

IMPORTANT: Your appliance is fitted with a safety features that will not allow it to function unless the processor bowl is fitted correctly. DO NOT attempt to override this feature.

Using the appliance

1. Make sure that the power cord is unplugged from the power outlet and the control dial (Fig.1F) is on the OFF position.
2. Always ensure that you use the processor on a stable, dry clean surface.

Using the Processor bowl

1. Place the drive shaft (Fig.1E) on the main body (Fig.1G), then fit the processor bowl (Fig.1D) over the top, lining up the handle with unlocked symbol.
2. Twist the handle anti-clockwise to lock the bowl into place (Fig.5B).

NOTE: Depending on the task required fit either the stainless steel blade (Fig.2H) or the slicing and grating disk (Fig.3I).

Using the processor bowl with the Stainless steel blade

The stainless steel blade is very versatile and can be used for chopping meat and vegetables, making salsa, stuffings, pates etc. The length of the processing will determine the fineness of the chopping and the texture achieved.

Place the Stainless Steel blade into the centre of the bowl over the top of the drive shaft.

Add the desired ingredients into the bowl.

NOTE: Do not over fill, if a large quantity is required it is better to do it in batches.

1. Fit the lid (Fig.1C) with the locking tab just to the left of the handle and turn anti-clockwise to lock into place (Fig.5A) - ensuring that the top of the drive shaft locates into the centre of the lid. The processor is now ready to use.

Tips for Stainless Steel blade

1. For best results cut food such as meat, bread, vegetables into similar sized pieces (approx 2-3 cm) before processing.
2. Biscuits should be broken into pieces and added down the feed chute whilst the machine is running.
3. When making pastry use fat straight from the fridge cut into 2 cm cubes.
4. You can always pour additional liquid through the feed chute whilst the machine is running to adjust the consistency of the mixture.
5. Always take care not to over process the ingredients, keep checking the mixture you can always process for longer if required.

Using the processor bowl with the slicing and grating disk

The slicing and grating disc (Fig.3I) will allow you to slice, grate or shred. The disc has two cutting sides one for slicing and one for grating and shredding. Place the disc with the function you require uppermost e.g. if you want to slice a carrot have the slicing blade facing upwards. Fit the lid and using the pushers (Fig.1A & B) slowly push the desired food stuff gently on to the blade do not force.

1. Place the slicing and grating disc on to the top of the drive shaft, with the cutting blade you require uppermost.

NOTE: The slicing and grating disc cannot be fitted with the blade in place

2. Fit the lid with the locking tab just to the left of the handle and turn anti-clockwise to lock into place (Fig.5A) - ensuring that the top of the drive shaft locates into the centre of the lid. The processor is now ready to use.

IMPORTANT: Do not operate continuously for more than 3 minutes, allow the machine to cool before re-using.

Tips for slicing and grating disk

1. Use Fresh Ingredients for best results.
2. Don't cut food too small. Fill the width of the feed chute as this prevents food from slipping sideways. Your processor has a large feed chute in the lid (Fig.1C) and a small feed chute (Fig.1B), use the feed chute that best fits the food you are cutting.
3. When using the slicer disc the size of the slice will depend on how you place the food in the feeder chute and which chute you use. Food placed to fill the feed chute will result in larger slices.
4. There will always be a small amount of waste on the disc after processing.

Using the Blender

1. Your blender has a removable blade (Fig.4N) for easy cleaning (see section Cleaning and Maintenance), Ensure the blade assembly is securely in place with the sealing ring (Fig.4M) properly fitted. To remove or replace the blade assembly twist in the direction of the arrows.
2. Place the jug (Fig.4L) onto the main unit lining up the arrow on the jug with the unlock symbol on the main unit and turn anti-clockwise to lock into place (Fig.5C).
3. Add ingredients. Fit the lid securely (Fig.4K), the blender is now ready to use.

Tips

1. When blending thick mixtures, e.g pates and dips they may need scraping down , if they are difficult to process add more liquid.
2. You can always remove the filler cap (Fig.4J) and add extra liquid as the machine is running to achieve the desired consistency.
3. When crushing ice add 15ml (1 tbsp) water to approx every 6 ice cubes and pulse using the turbo button.

IMPORTANT: Always cool hot liquids before blending.

NOTE: If blending warm liquids remove the filler cap and start at a low speed increasing to high speed if required. The pulse setting is not recommended for warm liquids. Do not blend warm liquids over the 1l level, and always take care to avoid contact with any steam.

Using The Control Settings

Pulse setting

The pulse setting is for when you want short sharp bursts of power and as soon as you release the button it will stop. This is ideal if you want to roughly chop something like tomatoes or peppers and you require control so that you don't end up with a pulp or finer mixture than required.

Setting 1 and 2

Settings 1 and 2 will operate continuously until you return the switch to the off position. Setting 2 being the faster and more powerful setting. When processing some ingredients you may want to use setting 1 and increase the power to setting 2 as and when required to give a boost to the process.

 **WARNING:** ALWAYS ENSURE THE POWER CORD IS UNPLUGGED FROM THE POWER OUTLET AND THE SPEED SELECTOR IS IN THE "0" OFF POSITION BEFORE ADDING OR REMOVING ANY OF THE ATTACHMENTS.

CLEANING AND MAINTENANCE

NOTE: Always clean removable parts immediately after use.

⚠ WARNING: BE CAREFUL WHEN CLEANING THE PARTS. AVOID TOUCHING THE BLADES AS THESE ARE EXTREMELY SHARP. NEVER IMMERSER THE MAIN HOUSING IN WATER OR ANY OTHER LIQUID

1. Always unplug the appliance before cleaning.
2. Disassemble all removable parts before cleaning.
3. Clean the main housing with a clean damp cloth and dry thoroughly. Ensure that the interlock areas are free from food.
4. Clean all removable parts in a dishwasher or in luke warm soapy water using a mild detergent.
5. Push access cord into the storage area in the bottom of the housing.

TROUBLESHOOTING

| | |
|---|---|
| Not turning on or functioning | Ensure that the processor lid and bowl are correctly fitted and locked into place (Fig.5A & B). This appliance has safety features that will not allow it to work unless it is correctly assembled. |
| Not blending satisfactorily | Ensure the food to be blended is in small manageable pieces approx. 2.5cm with cores and hard pieces removed and there is enough liquid to allow the food to move around and blend. If required remove the blender jug and add a little more liquid, ensure there is nothing jamming the blade replace the lid and place back on the motor unit. Using the pulse setting can help agitate the ingredients and move them around for better blending results. |
| Not processing satisfactorily | Sometimes if there is only a small amount to process, pulsing can help the ingredients to contact the blade and process more effectively. Pulsing can also allow larger quantities to be agitated and moved around for better and more accurate processing. This will also help avoid over processing. You may find with certain ingredients and small quantities removing the bowl and using a scraper to return ingredients to the centre of the processor will improve the result. |
| Blade or cutting disc not rotating, motor is running. | Ensure that the drive shaft is in place see Fig.1E |

WIRING

WARNING: IF THE SUPPLY CORD IS DAMAGED IT MUST BE REPLACED BY THE MANUFACTURERS SERVICE AGENT OR A SIMILARLY QUALIFIED PERSON IN ORDER TO AVOID A HAZARD.

The wires in the mains lead of this Food Processor are coloured in accordance to the following code:

Blue Neutral (N) Brown live (L)

This appliance is fitted with a 3 pin plug which has a 5amp fuse fitted.

If the plug supplied is not suitable for your socket or becomes damaged, it should be cut off and disposed of, and a suitable plug fitted as detailed below.

As the colours of the wires in the mains lead of this Food Processor may not correspond with the colour markings identifying the terminals in your plug, proceed as follows.

The wire which is coloured BLUE must be connected to the terminal in the plug which is marked with the letter 'N' or coloured BLACK or BLUE.

The wire which is coloured BROWN must be connected to the terminal in the plug which is marked with the letter 'L' or coloured RED or BROWN.

DO NOT connect either wire to the terminal in the plug which is marked with the letter 'E' or has the Earth symbol, or coloured GREEN or GREEN/YELLOW

WASTE ELECTRICAL & ELECTRONIC EQUIPMENT DIRECTIVE 2002/96/EC (WEEE)



At the end of this products life it should not be disposed of with general household waste.

Care should be taken to dispose of in a suitable manner in accordance with your Local Authority regulation.

PRODUCT REGISTRATION

Wahl are constantly developing and launching new products in the UK. We would like to understand your product needs and expectations and we value any comments you may have. As part of Wahl Customer Care, we are offering you the chance to be kept up to date with the latest product launches, innovations and special offers.

Please take a minute to register your product online at www.wahl.co.uk.

GUARANTEE

This product is guaranteed against defects in material and workmanship for a period of 2 years from the date of original purchase or receipt as a gift.

Should this product become defective during the guarantee period, return it to the store of purchase together with your proof of purchase for repair or replacement.

Alternatively within the guarantee period you can return the product to Wahl (UK) Ltd who will repair any such defect or elect to replace the product or any part of it, without charge, provided that there is proof of purchase. Should a replacement be offered this will not extend the original guarantee period.

The guarantee becomes invalid in the case of misuse, alteration or repair by unauthorised persons.

This product is designed for domestic use only and use within a professional environment will invalidate the guarantee.

This guarantee in no way affects your rights under statutory law in the United Kingdom.

Wahl (UK) Ltd
Herne Bay Trade Park
Herne Bay
Kent
CT6 8JZ
www.wahl.co.uk

Customer Service T: 01227 740066

Form No. ZB214
Rev0 06-17

james
MARTIN
by **WAHL®**